

Indicator of fault spot in the MV cable network type SMZ-3

Application:

The SMZ – 3 Indicator is independent small-dimensions device, installed in MV switchgear or MV/LV stations supplied from cable network, designed for fast location of the damaged section of this network.

The indicator shortens the time of locating the damaged network section, decreasing losses resulting from the non-supplying the energy.

Characteristic feature :

- It detects the short-circuit current flow in case of:
 - earth fault, by measurement of zero current
 - phase-to-phase short, by measurement of phase currents
- It can be used in cable networks with voltage from 6 to 36KV operating with the neutral point:
 - isolated
 - compensated with Petersen coil independently from installed or not AWSC automation
 - earthed by resistor
- The current sensors can be mounted onto cables:
 - individual (every conductor shielded separately)
 - traditional (one common screen for three conductors)
- It co-operates with phase current comparators equipped with fibre optic outputs.
- It performs the measurement of zero current on the base of:
 - single Ferranti transformer (magnetical adding up) comprising together three conductors, with magnetic core diameter of 150mm.
 - three transformers operating in Holmgreen's system (electric adding up) comprising separately every conductor, with magnetic core diameter of 100mm.
- Simple adaptation to any network is done through the wide range of settings programmed with rotary switches.
- It enables internal and external light signalling, separately for phase-to-phase short-circuit and earth fault
- It is equipped with two-colour external light indicator with good visibility, resistant to vandalism (manufactured in the way making impossible the theft or disassemble without access to the interior of the station)
- It co-operates with telemechanics systems through:
 - relay outputs indicating independently the earth fault and phase-to-phase short-circuit
 - galvanic separated inputs of remote testing and alarm resetting with direct voltage 24V

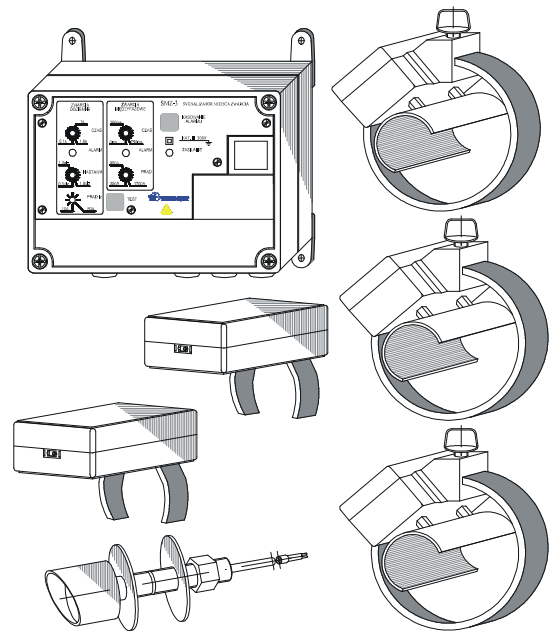

Location of damaged section of cable network

The cable network should be divided on sections and the SMZ -3 indicator should be installed at the start of every section. The occurrence of earth fault or phase-to-phase short-circuit in one of the sections will activate an alarm generated by indicators placed between the short-circuit spot and the supply (GPZ). The following diagram illustrates such a case.

Alarm at earth fault:

- the external and internal red light flicker
- the contacts of adequate bistable relay

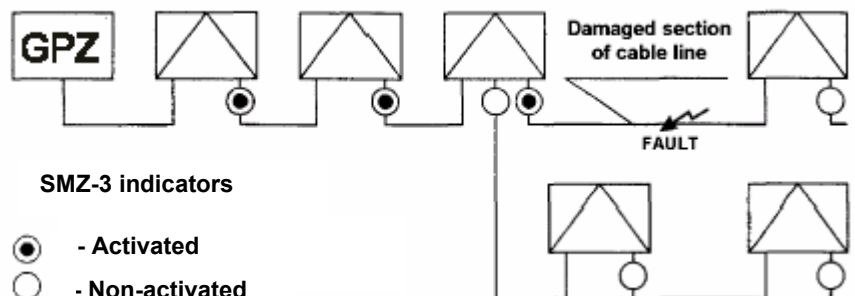

Alarm at phase-to-phase short circuit:

- the external and internal light flicker alternate in red and green
- the contacts of adequate bistable relay are closed

Light indication of fault current flow placed outside the station building enables the network supervising personnel to determine in the simple and fast way the last station in a cable line, counting from GPZ, through which the fault current has flown. This unequivocally corresponds with the location of damaged section of the cable line.

Required settings when detecting the earth faults:

Depending on conditions in the network as well as its type one should set the following values with rotary switches located in the central unit:

- the zero current threshold value, above which the alarm is generated: in the range from 3 to 144A.
- the minimum time of short-circuit duration, above which the alarm is generated in the range from 0,1 to 1,6 second.

Required settings when detecting the phase-to-phase short circuits:

By rotary switches located in central unit or fibre optic comparators one should set:

- the phase current threshold value, above which the alarm is generated:
 - in the range from 200 to 1700A when using phase comparators
 - in the range from 200 to 900A when using current transformers
- the minimum time of short-circuit duration, above which the alarm is generated in the range from 0 to 750 ms.

The manufacturer can provide the assistance in determining the optimum settings for earth faults: sensitivity and alarm time delay for the individual indicators located in any point of the network with taking into consideration its various configurations.

The calculations are carried out using computer software on the basis of the network topography provided by the user.

The software enables to determine the zero currents occurred in any point of the network during simulated one-phase earth fault, and on this basis, to determine optimum settings and then to carry out simulation of behaviour of all indicators installed in this network.

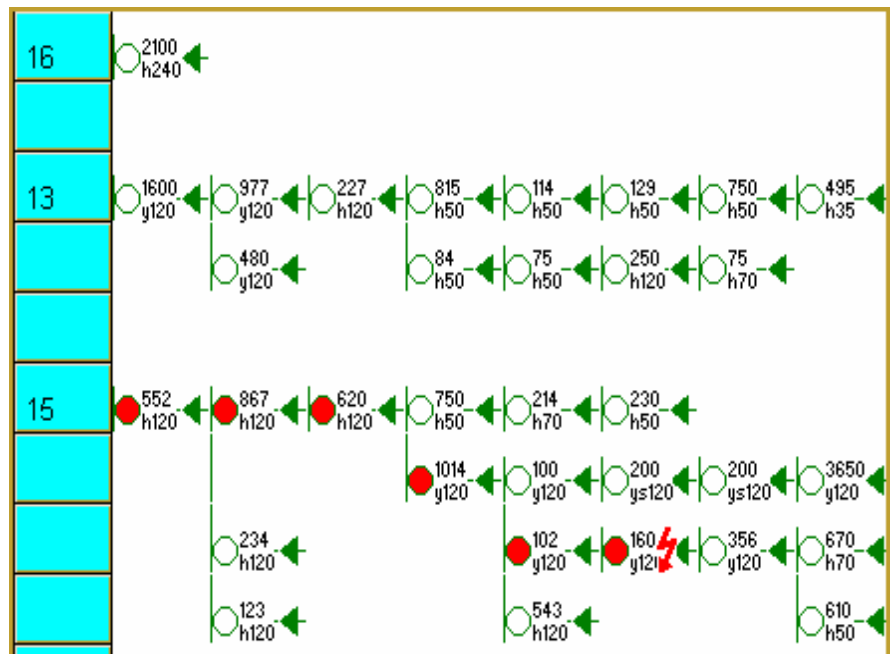

Technical data:

Supply	
Basic supply	230V~+10%-15%, 50Hz±5%
Emergency supply	2xNiCd 700mAh, 1.2V
Power consumption at basic supply	max 2VA (c.a. 1,5W)
Time needed for full charging the batteries	min. 48 hrs.
Parameters of MV network	
Voltage	from 6 to 36KV~ 50Hz
Operating conditions of neutral point	Isolated, compensated or earthed through resistor
Earth faults detection	
Setting of zero current threshold value ¹	3+18 step 1A; 18+36 step 2A; 36+90 step 3A; 90+120 step 4A; 120+144 step 8A; ±5%
Minimum required fault duration time	0.1+1.6 sec.; settings with step 0.1s ±5%
Phase-to-phase short circuits detection	
Setting of phase current threshold value for current transformers	200A ÷ 900A ; settings with step 100A; ±5%
Setting of phase current threshold value for fibre optic comparators	200A ÷ 1700A ; settings with step 100A; ±5%
Minimum required fault duration time	0 ÷ 750ms ; settings with step 50ms ±5% (0 means c.a. 15ms.)

Alarm signalling – at once after fault appearance				
Alarm signalling for earth fault	Flashing external and internal red light and closing the contacts of bistable relay			
Alarm signalling for phase-to-phase short circuit	Flashing external and internal light alternate in red and green colour and closing the contacts of bistable relay			
Flashing frequency	every 1 second			
Alarm signalling time when operating on batteries	4hrs.			
Alarm resetting				
Automatically after return of MV (after the abatement of short circuit)	after 10s presence of middle voltage			
Automatically after return of 230 V supply (after the abatement of short circuit)	after 10s under the condition of permanent presence of basic 230V supply voltage			
Automatically	after 4hrs. or when the voltage on batteries poles reaches 2 V			
Remote (after the abatement of short circuit)	by direct voltage 24V- from telemechanics systems			
Manually (after the abatement of short circuit)	By pushbutton on central unit front panel			
General technical data				
Vigilance time after basic voltage loss	60s (This function protects the battery against deep discharging)			
Indication of basic supply voltage loss	flickering internal yellow light (flickering period 0,1s step 1s)			
Signalling of batteries charge state	YES – at presence of basic supply voltage			
- weak	- flickering internal yellow light (flickering period 0,5s step 1s)			
- good	- internal yellow light lighted continuously			
Contact load in alarm relays	1A, 250V~			
Efficiency test of whole measuring circuit	YES – by pushbutton or direct voltage 24V- from telemechanics system			
Class of protection	II acc. EN 61140:2002			
Isolation electric strength	2300V r.m.s., 50Hz, 60s acc. EN 61010-1			
Ambient operating conditions	Central unit	transformers	comparators	Light indicator
Range of operating temperature	-25 ÷ 55°C	-40 ÷ 55°C	-25 ÷ 55°C	-40 ÷ 70°C
Range of storage temperature	-40 ÷ 70°C	-40 ÷ 70°C	-40 ÷ 70°C	-40 ÷ 70°C
Humidity (without steam condensation)	max 90%	max 90%	max 90%	max 95%
Housing degree of protection acc. EN 60529	IP 65	IP 40	IP 40	IP 65

1) with application of three transformers in Holmgreen's system the threshold value should be set above 20A especially with high phase currents, exceeding 300 A.

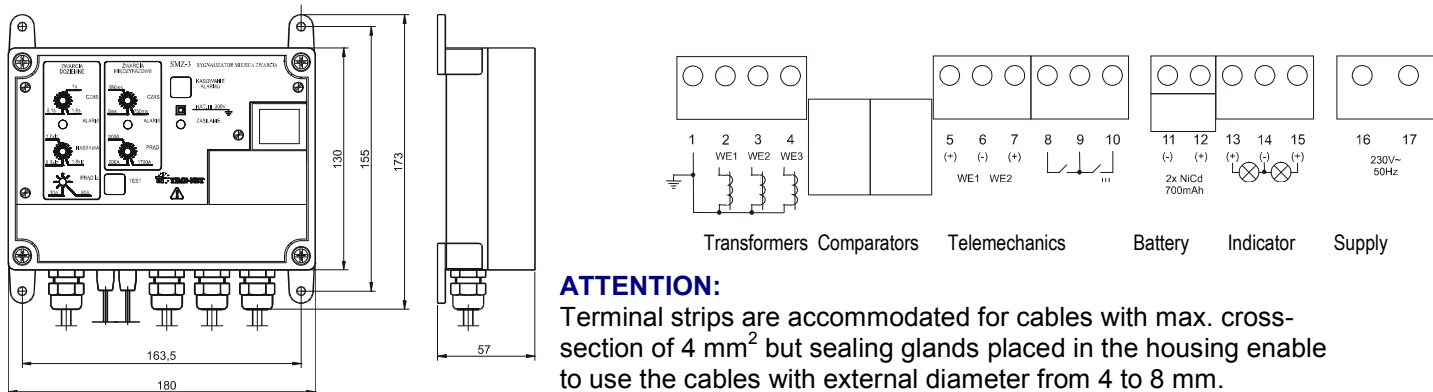
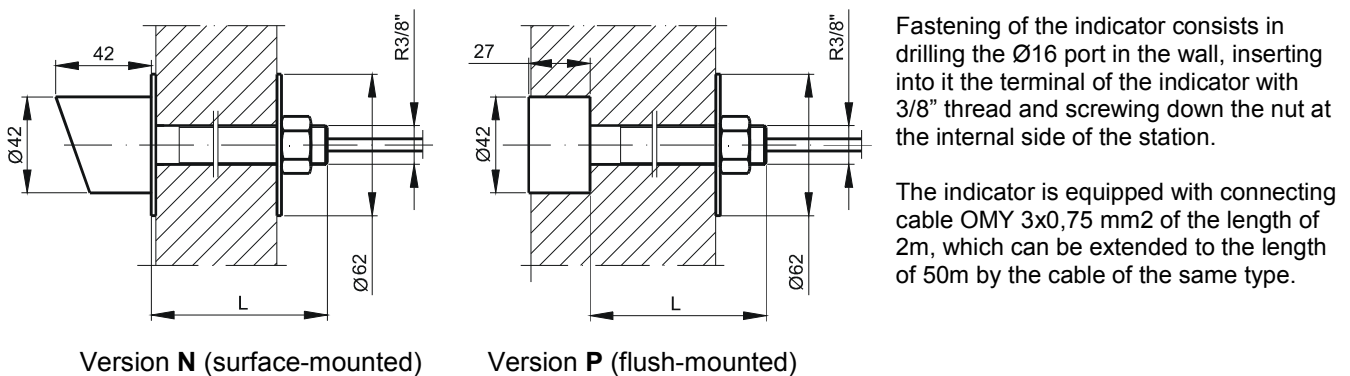
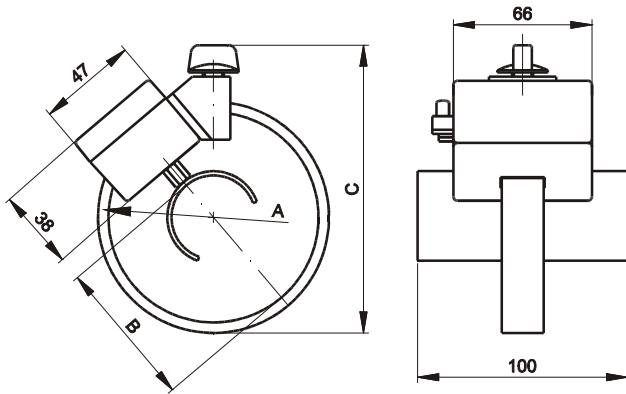

Fig. 1 View and dimensions of SMZ – 3 central unit



At choice standard dimensions „L”: 150 or 440mm (others on agreement)

Fig. 2 Dimensions and fastening of light indicator



Magnetic core	A	B	C
Ø100	100	70	140
Ø150	150	110	190

Fig. 3 Dimensions of transformers

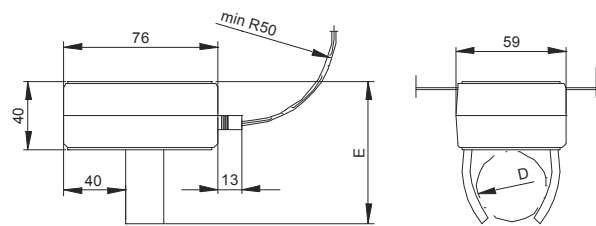

version	D	E
K40	Ø 30÷50	80
K65	Ø 65	90

Fig. 4 Dimensions of comparators

ATTENTION:

The current transformers and comparators fibre optic are adapted for fast and easy mounting onto the cable by one person, which shortens to the minimum the voltage outage time necessary for mounting the device.

The indicator set contains:

- microprocessor control unit type SMZ-3 in housing, for mounting directly on internal wall of the station,
- light indicator for mounting on station building outer wall at the place well visible from the access road
- current relays, depending on chosen type, according to the following table:

Type of device	Current transformers		Fibre optic comparators	Designed for detecting the faults:
	Magnetic core Ø150	Magnetic core Ø 100		
SMZ-3/1	1pc.	-	-	only earth faults
SMZ-3/2	1 pc.	2 pcs.	-	earth and phase-to-phase
SMZ-3/K*	1 pc.	-	2 pcs.	earth and phase-to-phase
SMZ-3/3	-	3 pcs.	-	earth and phase-to-phase
SMZ-3/3K*	-	3 pcs.	2 pcs.	earth and phase-to-phase

*) Phase current comparators with fibre optic outputs are manufactured in following versions:

40 – with destination for mounting onto cables with diameter from 30 to 50mm

65 - with destination for mounting onto oil cable head 3GOw-A or cable with diameter approx. 65mm

As a standard each comparator is equipped with fibre optic cable of the length of 5 m (optionally 10m)

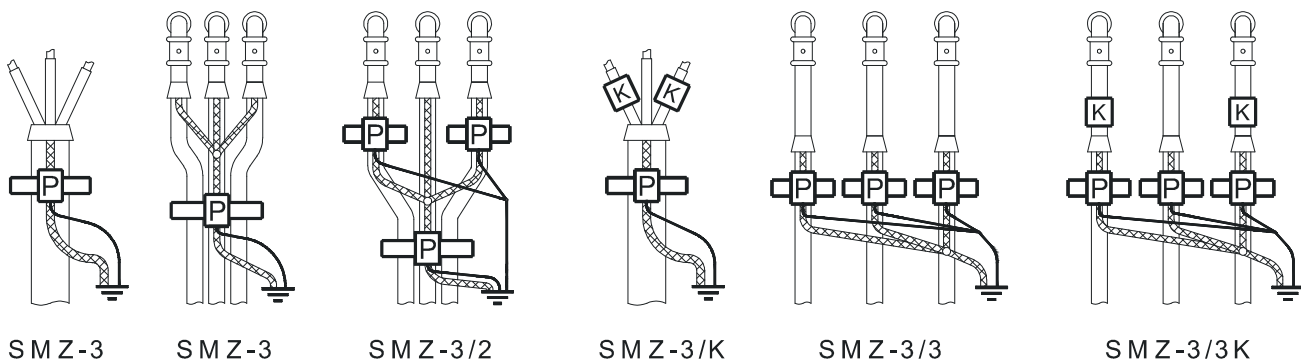

Fig. 5 Assembly of current transformers and comparators onto MV cables

Define when ordering: type of device/description of light indicator

where:

type of device

- the type chosen from the table above

description of light indicator

- N (surface-mounted) or P (flush-mounted) and „L” dimension given in [mm]

The example of the order: SMZ-3/3K65/P440

Manufacturer reserves the right to make changes in construction of the product.