

SMZ 4 SHORT-CIRCUIT SIGNALLING DEVICE IN MV CABLE NETWORKS

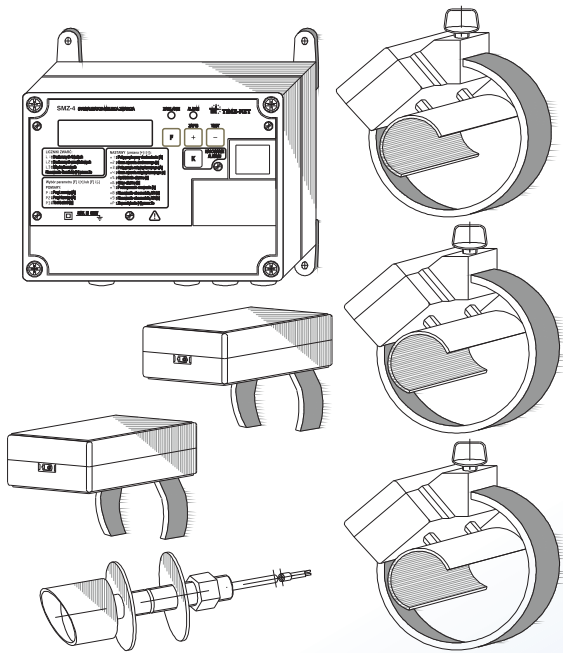

The signalling device SMZ-4 is a small independent instrument which is installed in MV switching stations or in MV/LV stations powered from a cable network whose purpose is fast localization of a defective section of the network.

The device limits the time of localization of the defective section of the network and diminishes the losses caused by stoppage in power supply.

Characteristics:

The device detects the short-circuit current:

- the ground one through measurement of zero current
- inter-phase one through measurement of phase current

The device may be used in cable networks of the current between 6 and 36 kV that are working with a isolated, compensated with a Petersen coil or grounded through a resistor neutral point.

Voltage transformers may be installed on:

- single cables (each conductor with separate shielding)
- traditional cables (one common shield for three conductors)

Works with phase current comparators with light pipe outputs

Measures zero current on the base of:

- single Ferranti transformer (magnetic summation) including three conductors simultaneously with the diameter of the magnetic core of 150 mm.
- three transformers working in the Holmgreen system (electric summation) including one conductor at a time; the diameter of the magnetic core is 100 mm.

Facilitates simple adaptation for any network by programming of many different settings with a high resolution by means of a keyboard and an LCD display in the memory.

Shows on the LCD display the number of registered permanent, grounded, temporary short-circuits and the number of registered inter-phase short-circuits.

Functions for approximately seven years with a local battery power-supply (lithium battery 3.6 V/17 Ah), so it may be installed in switching stations that do not have 230 V power supply.

It may be powered with 24 V direct current at the current-carrying capacity of 50 mA.

It facilitates internal and external light signalling separately for inter-phase and ground short-circuits.

It is equipped with two-coloured (red and green) external heavy-duty signalling device of good visibility (made in a manner that prevents theft or dismantling without access to the interior of the station).

It works with telemechanics systems through:

- transformer outputs (no-current contacts) independently indicating ground and inter-phase short-circuit
- galvanically separated remote testing and 24 V direct current alarm reset inputs

Location of a defective section of the cable network

Cable network should be divided into sections and at the beginning of each of them an SMZ-4 signalling device should be installed. Ground or inter-phase short-circuit in any of the sections will cause an alarm generated by signalling devices located between the short-circuit and power supply (PS).

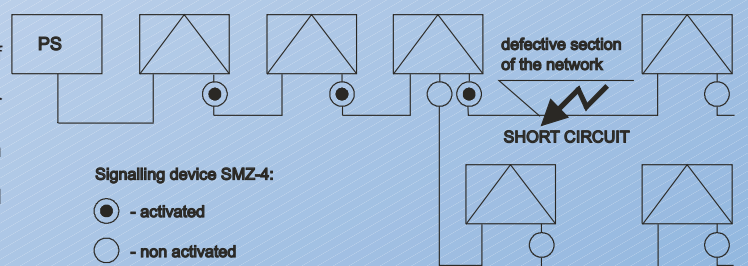

Alarm in the case of ground short-circuits:

- blinking internal and external red lamp
- short-circuit of contacts of appropriate bi-stable transformer

Alarm in the case of inter-phase short-circuits:

- blinking internal and external red and green lamp
- short-circuit of contacts of appropriate bi-stable transformer

Light signalling of short-circuit current outside the building of the stations allows for fast and simple determining the last station in the cable series counting from the power supply through which the inter-phase or ground short-circuit passed. It means localisation of the defective section of the network.

Required settings at detection of ground short-circuit:

Depending on the conditions in the network and its type, set the following by means of the keyboard and the display:

- the threshold value of the zero current above which an alarm signal will be generated within the range between 3 and 160 A.
- minimum time the short-circuit lasts above which an alarm signal will be generated within the range between 0.5 to 6.5 s.
- delay time for the alarm signalling that is needed to mask temporary short-circuits within the range between 0 and 240 s.

Required settings at detection of inter-phase short-circuit:

Depending on the conditions in the network and its type, set the following by means of the keyboard and the display in the central unit:

- the threshold value of the phase current above which an alarm signal will be generated:
 - within the range between 200 and 1700 A using phase comparators
 - within the range between 200 and 1500 A using current transformers
- minimum time the short-circuit lasts above which an alarm signal will be generated within the range between 0 to 0.75 s.

The manufacturer offers assistance in determination of optimum settings for ground short-circuits: sensitivity and delay of the alarm for individual signalling devices located at any point of the network, taking into account its different configurations.

Calculations are realised by means of a computer programme on the basis of the topography of the network supplied by the user. The programme makes it possible to determine zero current in the network at any of its points during simulated, one-phase ground short-circuit and to determine on that basis optimum settings and then to realise a simulation of reaction of all the existent signalling devices.

Technical data:

Power supply	
External power supply (see offered versions)	230 V ~ + 10%-15%, 50 Hz ± 5%, max. 2 VA (approximately 1.5 W) or direct current 24 V -/50 mA
Internal power supply (see offered versions)	Lithium battery 3.6 V/17Ah (R20) preferably LS 33600 by SAFT
Working time with one lithium battery	Approximately seven years including 200 h of alarm signalling
Durability of a lithium battery	10 to 15 years depending on the particular piece
Parameters of an SN network	
Voltage	6 to 36 KV ~ 50 Hz
Operational conditions for the neutral point	Insulated, compensated or grounded through a resistor
Detection of ground short-circuits	
Setting of threshold value for the zero current ¹	Current threshold with grounding 3 A to 160 A set every 1 A ± 5%
Minimum required duration of a short-circuit	Ground short-circuit duration 0.05 to 6.50 s. set every 0.05 s ± 5%
Delay of alarm signalling that permits to eliminate signalling of temporary short-circuits	Delay of alarm signalling 0 s to 240 s set every 10 s ± 5%
Detection of inter-phase short-circuits	
Setting of threshold value for the phase current for phase transformers	Threshold value for the phase current 200 A to 1500 A set every 100 A ± 5%
Setting of threshold value for the phase current for light pipe comparators	Threshold value for the phase current 200 A to 1700 A set every 100 A ± 5%
Minimum required duration of a short-circuit	Duration of inter-phase short-circuit 0 s to 0.75 s set every 0.05 s ± 5%, where "0" means approximately 15 ms
Alarm signalling	
Alarm signalling for ground short-circuit	Blinking internal and external optical indicator in red and short-circuit of contacts of the bistable transmitter
Alarm signalling for inter-phase short-circuit	Blinking internal and external optical indicator in red and green and short-circuit of contacts of the bistable transmitter
Blinking period	Every second

Cancellation of alarms				
Automatic at a medium voltage unless the defect does not disappear		MV cancellation 0 to 15 s set every 5 s \pm 5%		
Automatic after low voltage has returned unless the defect does not disappear		LV cancellation 0 to 15 s set every 5 s \pm 5%		
Automatic after the programmed time		"0" switches off the functions		
Remote		Alarm time 1 h to 8 h set every hour \pm 5%		
Manual		Direct current 24 V – from telemechanics systems		
Manual		With a button on the front panel of the central unit		
Test functions				
Ground and inter-phase short-circuit counters		Yes – shown on the LCD display every two seconds: L1 – permanent ground short-circuits, L2 – temporary ground short-circuits, L3: inter-phase short-circuits		
Measurement of ground and inter-phase current		Yes – after the measurement function has been switched on		
Measurement of battery voltage		Yes – after the measurement function has been switched on		
Test of efficiency of the whole measurement section and the state of the lithium battery		Yes – with a button or direct current 24 V – from telemechanics systems (revision of all measurement circuits and duty test of the lithium battery)		
Indicator of the state of the battery		Yes – the LCD display blinks if the voltage of the battery drops below 2.6 V)		
General technical data				
Signalling of external power supply		Yellow indicator (LED diode on the front panel of the control unit)		
Signalling of middle voltage		Lit point on the LCD display		
Transmission of the applied current transformers		1/2500		
Current-carrying capacity for contacts in alarm transmitters		1 A, 250V~		
Protection class		II with accordance to EN 61140:2002		
Electrical endurance of the insulation		2300 V r.m.s, 50 Hz, 60 s, with accordance to EN 61010-1		
Climatic operational conditions	Central unit	Measuring transformers	Comparators	Light signalling device
Range of working temperature	- 25 – 55°C	- 40 – 55°C	- 25 – 55°C	- 40 – 70°C
Range of storage temperature	- 30 – 70°C	- 40 – 70 °C	- 40 – 70°C	- 40 – 70°C
Humidity (without steam precipitation)	Maximum 90%	Maximum 90%	Maximum 90%	Maximum 95%
Protection grade of the casing with accordance to EN 60529	IP65	IP40	IP40	IP65

1) in the case of application of three measuring transformers in the Holmgreen system, the threshold value should be set above 20 A, particularly at high phase current that exceeds 300 A.

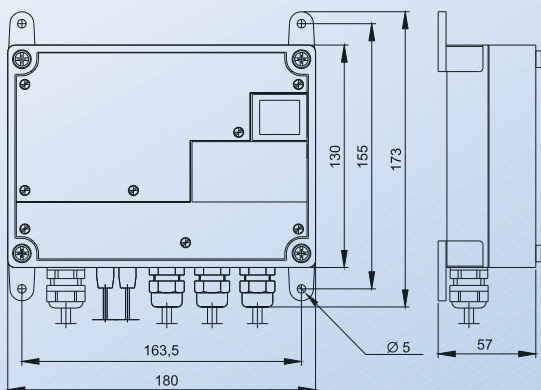

Note:

- fastening boards are adapted for cables whose maximum diameter is **2.5 mm²** while stuffing boxes located in the casing make it possible to use cables of external diameter between **4 and 11 mm** for the cord of the measuring transformers and **4 to 8 mm** for other cords,
- clamps **3, 4, 10 and 13** are not present in versions **1 and 2**
- clamps **16 and 17** are not present in version **D**
- clamps **11 and 12** and the battery box are not present in version **C**

Description of versions see table on the last page.

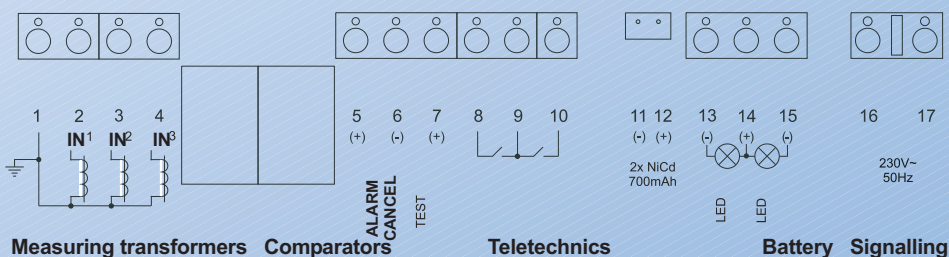

Drq.1: Measurements and fastening board rail

Installation of the signalling device consists in drilling in the wall an open hole whose diameter is 16 mm, passing the tip of the signalling device through it (the diameter of the thread is 3/8") and placing a nut on the external side of the station.

The signalling device is normally equipped with a connection cord OMY 3 x 0.75 mm² or OMY 2 x 0.75 mm² whose length is 2 m and which may be extended with a cable of the same kind to the length of 50 m.

Standard dimensions "L" to be chosen are: 150 or 440 mm (or others having been previously agreed upon)

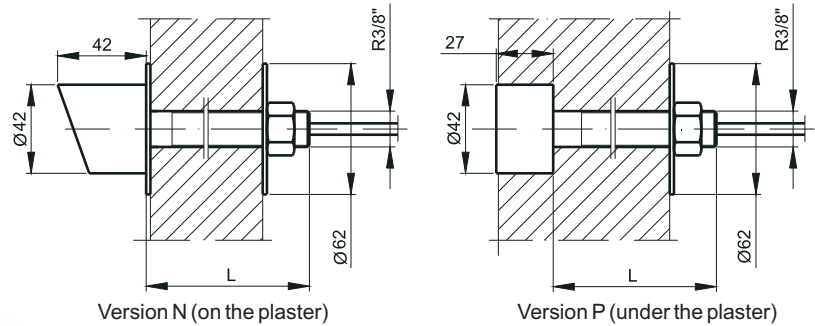

Drg.2: Dimensions and installation of the light signalling device

Installation of the signalling device consists in drilling in the wall an open hole whose diameter is 16 mm, passing the tip of the signalling device through it (the diameter of the thread is 3/8") and placing a nut on the external side of the station.

The signalling device is normally equipped with a connection cord OMY 3 x 0.75 mm² or OMY 2 x 0.75 mm² whose length is 2 m and which may be extended with a cable of the same kind to the length of 50 m.

Standard dimensions "L" to be chosen are: 150 or 440 mm (or others having been previously agreed upon)

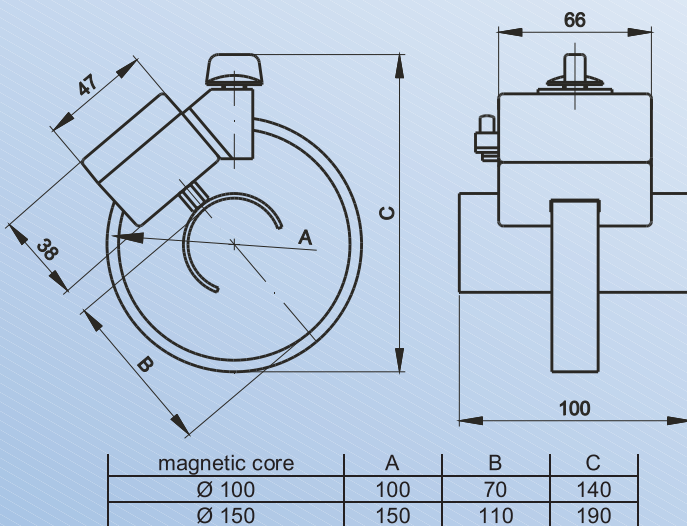

Drg. 3: Dimensions of measuring transformers

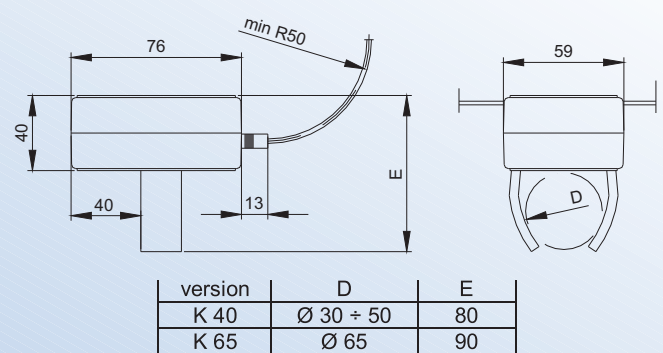

Drg. 4: Measurements of comparators

NOTE:

Current transformers and light pipe comparators are prepared for quick and easy installation that may be carried out by one person what maximally reduces the period when the current is turned off due to installation.

A set is formed by:

- micro processing control unit SMZ 4 in a casing for installation directly on the internal wall of the station,
- light signalling device to be installed on the external wall of the building where it will be visible from the access road,
- current transformers depending on the chosen version with accordance to the following table:

Versions that differ with regard to equipment	Versions that differ with regard to the power supply voltage				Current transformers of the following diameter of the magnetic core		Light pipe comparators	Versions whose purpose is detection of: d – ground short-circuits m – inter-phase short-circuits
	A	B	C	D	D = 150	D = 100		
1	SMZ-4/1	SMZ-4/24B	SMZ-4/24	SMZ-4/DB	1 pce.	-	-	d
2	SMZ-4/3P	SMZ-4/24B/3P	SMZ-4/24/3P	SMZ-4/DB/3P	-	3 pcs.	-	d
3	SMZ-4/2	SMZ-4/24B/2	SMZ-4/24/2	SMZ-4/DMB/2	1 pce.	2 pcs.	-	d & m
4	SMZ-4/3	SMZ-4/24B/3	SMZ-4/24/3	SMZ-4/DMB/3	-	3 pcs.	-	d & m
5	SMZ-4/K*	SMZ-4/24B/K*	SMZ-4/24/K*	-	1 pce.	-	2 pcs.	d & m

Versions presented in column:

A are powered with low voltage 230 V~ and a lithium battery 3.6V/17Ah

B are powered with direct current 24 V and a lithium battery 3.6V/17Ah

C are powered solely with direct current 24 V

D are powered solely with a lithium battery 3.6V/17Ah

*) Phase current comparators with light pipe outputs are made in the following versions:

40 to be installed on cables whose diameter is 30 to 50 mm

65 to be installed on the oil cable head 3Gow-A or on a cable whose diameter is approximately 65 mm

Each comparator is normally equipped with a light pipe cord whose length is 5 m (optionally up to 10 m)

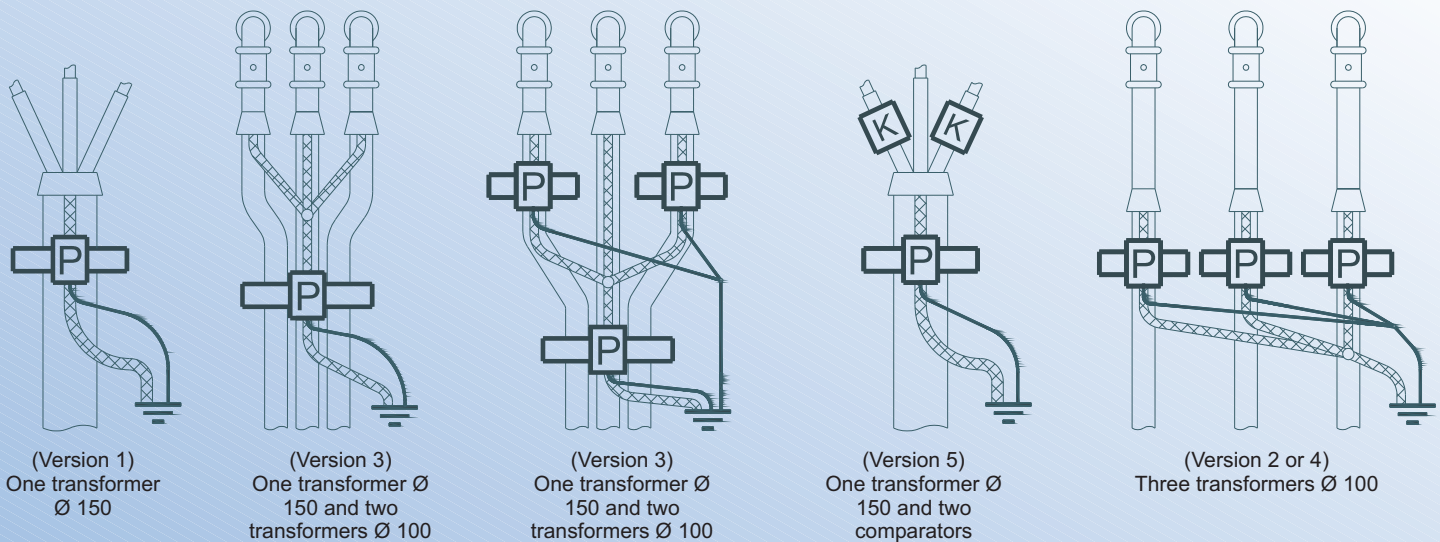

Drg. 5: Installation of current transformers and comparators on SN cables depending on the version.

To be determined on placement of an order:

Type of device chosen from the table, e.g.: SMZ-4/DMB/2

Description of the light signalling device, e.g.: installed on the plaster L=150mm